



CleanLine™

TECHNICAL BULLETIN

General. Manufactured of 6063 Alloy containing Silicon and Magnesium as the major alloying elements, contributing to good strength, corrosion resistance, weldability, and machinability.

According to the Aluminum Extruders Council (AEC) publication *Extrusion Spotlight Alloys*, aluminum alloyed in the 5XXX and 6XXX series contains the following desirable properties: 1. Very lightweight, one-third that of steel and concrete. 2. High strength, comparable to steel and steel/concrete composites. 3. Strength and ductility as high or higher at sub-zero temperatures than at room temperature. 4. Exceptional corrosion resistance. 5. Ease of fabrication by many techniques, including extrusion, to unique advantageous structural configurations. *This publication can be found at www.aec.org.*

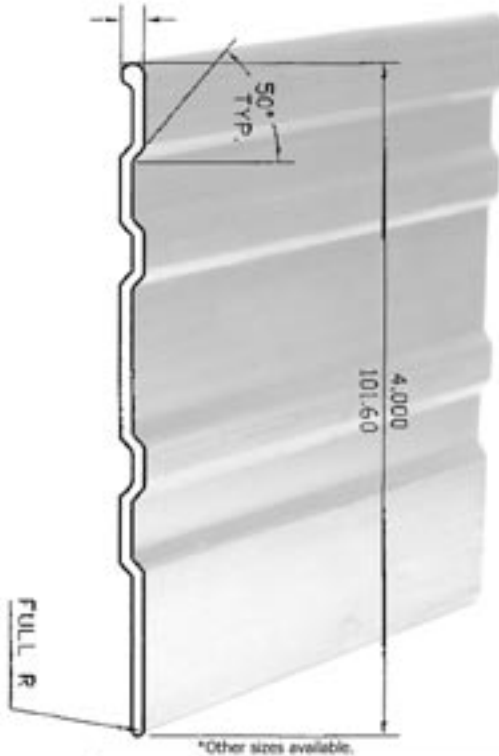

Additional Information

Extreme Low Temperature. The many advantages of extruded aluminum are not impaired by exposure to low temperatures. Aluminum actually gains strength as temperature is reduced, making it an appropriate metal for Arctic, space or cryogenic applications.

Ultraviolet Radiation. Sunlight includes ultraviolet (electromagnetic) radiation which causes tanning or sunburn in human skin, and which may cause chemical or structural changes in some commercial materials. Aluminum, however, reflects ultraviolet radiation and is not damaged by it.

Combustability. Extruded aluminum will not burn, which makes it safer than many other materials, such as wood, paper, or plastic for design applications. Extruded aluminum does not emit any toxic, hazardous fumes when exposed to high temperatures.

Alloy 6063 Chemical Analysis

Liquidus Temperature: 1211°F Solidus Temperature: 1139°F Density: 0.097 lb./in.³

Percent Weight	Elements									Others Each	Others Total	Aluminum
	Si	Fe	Cu	Mn	Mg	Cr	Zn	Ti				
Minimum	.20	—	—	—	.45	—	—	—	—	—	—	Remainder
Maximum	.6	.35	.10	.10	.9	.10	.10	.10	.05	.15		

Average Coefficient of Thermal Expansion (68° to 212°F) = 13.0 x 10⁻⁶ (inch per inch per °F)

Alloy 6063 Mechanical and Physical Property Limits

Temper	Specified Section or Wall Thickness ² (inches)	Tensile Strength (ksi)				Elongation ³ Percent Min. in 2 inch or 4D ⁴	Typical Brinell Hardness (500 kg load/10 mm ball)	Typical Ultimate Shearing Strength (ksi)	Typical Electrical Conductivity (%IACS)
		Ultimate		Yield (0.2% offset)					
		Min.	Max.	Min.	Max.				
T6	.125-1.000	30.0	—	25.0	—	10	73	22	53

① The mechanical property limits for standard tempers are listed in the "standards section" of the Aluminum Association's Aluminum Standards and Data manual and Tempers for Aluminum and Aluminum Alloy Products. ② The thickness of the cross section from which the tension test specimen is taken determines the applicable mechanical properties. ③ For material of such dimensions that a standard test specimen cannot be obtained, or for shapes thinner than 0.062", the test for elongation is not required. ④ D = Specimen diameter.

Characteristics of Alloy/Temper¹

Alloy	Temper	Formability		Machinability				General Corrosion Resistance				Weldability (Arc with Inert Gas)				Brazeability				Anodizing Response				Electrical Conductivity (%IACS) @ 68°F		
		Low	High	D	C	B	A	D	C	B	A	D	C	B	A	D	C	B	A	D	C	B	A	40	50	60
6063	-T6	—	—	—	—	—	—	—	—	—	—	—	—	—	—	—	—	—	—	—	—	—	—	—	—	—

① Rating: A=Excellent B=Good C=Fair D=Poor For further details of explanation of ratings, see Aluminum Association's Aluminum Standards and Data manual.

Material content provided courtesy of Alcoa